



EFFECTIVE FROM  
JANUARY 2024

EXPORT CATALOGUE  
**TYRE CHANGERS**  
AND ORIGINAL ACCESSORIES



REL. JULY 2024

# COLOR TABLE

- 1) The standard company colour of our equipment is blue RAL 5015 (→ /25).
- 2) On demand other colours are available (see RAL table)\*.

• Below the table for the colors:

	→ /25	RAL 5015 Blue sky
	→ /A4	RAL 5011 Blue (Peugeot)
	→ /22	RAL 5011 Blue (Peugeot) orange-peel
	→ /16	RAL 3002 Red
	→ /45	RAL 1003 Yellow (Renault)
	→ /38	RAL 7042 Grey (Renault)
	→ /39	RAL 7040 Window grey (Volkswagen / Porsche / Fiat)
	→ /33	RAL 7011 Grey (Mercedes)
	→ /65	RAL 7012 Grey (Mercedes)
	→ /52	RAL 7015 Grey (Mercedes)
	→ /69	RAL 7030 Stone grey (Ferrari / Maserati)
	→ /34	RAL 7016 Anthracite grey (BMW)

• Different colors subject to confirmation of the Export dept.

\* : The equipment in different color than standard can be subject to surcharge.

The pictures included in the present illustrated catalogue, are only intended to show the product and are therefore not binding. The company reserves the right to make in every moment and without prior notice, any modification deemed necessary.

NEXION S.p.A. declines any responsibility for any complaint coming from the use of not original accessories or spares with consequent forfeiture of the CE conformity declaration.

# TABLE OF CONTENTS

<b>“LEVER-LESS” UNIVERSAL TYRE CHANGERS</b>	<b>5</b>
M 1032 series	4
M 1028	7
M 928 ROYAL	8
M 830 LL	9
M 830 M	10
OPTIONAL ACCESSORIES FOR “LEVER-LESS” UNIVERSAL TYRE CHANGERS	18
<b>“LEVER-LESS” PASSENGER CAR TYRE CHANGERS</b>	<b>20</b>
M 824 LL series	20
OPTIONAL ACCESSORIES FOR M 824 LL	22
<b>PASSENGER CAR TYRE CHANGERS</b>	<b>25</b>
M 724S series	25
M 624 series	26
M 522 series	27
M 424 A series	29
M 424 series	31
M 422 series	33
M 322 FS - M 322 series	35
OPTIONAL ACCESSORIES FOR PASSENGER CAR TYRE CHANGERS	38
<b>MOTORCYCLE TYRE CHANGERS</b>	<b>47</b>
M 322 BIKE	47
OPTIONAL ACCESSORIES FOR M 322 BIKE	48
M 200 BIKE	49
OPTIONAL ACCESSORIES FOR M 200 BIKE	50
<b>HEAVY-DUTY TYRE CHANGERS</b>	<b>53</b>
F 565	52
F 562	53
F 562 M	54
F 560 - F 560 A SPECIAL	55
F 560 - F 560 A SPECIAL Y	56
F 560 A	57
F 560	58
F 260	59
F 240 A	60
F 230 MOBILE	61
F 226 MOBILE	62
OPTIONAL ACCESSORIES FOR HEAVY-DUTY TYRE CHANGERS	63
DIAGRAM OF PACKING SPECIFICATION	70



# "LEVER-LESS" UNIVERSAL TYRE CHANGERS

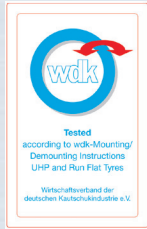

**LEVER-LESS & Contact-Less**  
Technologies

**HYDRAULIC Power**

Ciclo di smontaggio  
**AUTOMATICO**



M 1032 DIAMOND A

## M 1032 P.L. series



- All models supplied with:
- 1 Complete universal locking pistol
  - 1 Wheel centering cones set
  - 1 Pair of PPT plastic bead clamp
  - 3 Plastic rim protections
  - 3 Short plastic rim protections
  - 2 Bead protection plastic lever
  - 1 Set of plastic inserts for tool head (Revolver)
  - 1 Brush for bead lubrication
  - 1 Sliding bead pressing clamp
  - 1 Operator's manual

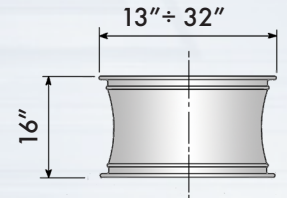

**M 1032**

PN	Power supply	Description
0-11201306/25	200-230V/1Ph/50-60Hz	<b>M 1032 SILVER P.L.</b>
0-11201310/25	200-230V/1Ph/50-60Hz	<b>M 1032 STD A P.L.</b> - With AUTOMATIC demounting cycle.
0-11201311/25	200-230V/1Ph/50-60Hz	<b>M 1032 SILVER A P.L.</b> - With AUTOMATIC demounting cycle.
0-11201307/25	200-230V/1Ph/50-60Hz	<b>M 1032 GOLD P.L.</b>
0-11201308/25	200-230V/1Ph/50-60Hz	<b>M 1032 DIAMOND A</b> - With AUTOMATIC demounting cycle.



: New or Modified Item



# "LEVER-LESS" UNIVERSAL TYRE CHANGERS

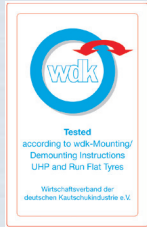

**LEVER-LESS & Contact-Less**  
Technologies

**HYDRAULIC Power**



## M 1032 S.L. series



- All models supplied with:
- 1 Complete universal locking pistol
  - 1 Wheel centering cones set
  - 1 Pair of PPT plastic bead clamp
  - 3 Plastic rim protections
  - 3 Short plastic rim protections
  - 2 Bead protection plastic lever
  - 1 Set of plastic inserts for tool head (Revolver)
  - 1 Brush for bead lubrication
  - 1 Sliding bead pressing clamp
  - 1 Operator's manual

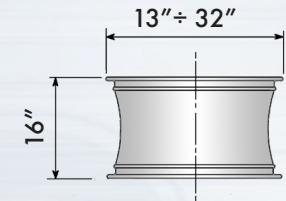

## M 1032 S.L. series

PN	Power supply	Description
0-11201301/25	200 - 230V/1Ph/50-60Hz	<b>M 1032 STD</b>
0-11201302/25	200 - 230V/1Ph/50-60Hz	<b>M 1032 SILVER S.L.</b>
0-11201304/25	200 - 230V/1Ph/50-60Hz	<b>M 1032 GOLD S.L.</b>



: New or Modified Item

# "LEVER-LESS" UNIVERSAL TYRE CHANGERS

## M 1032 series SUMMARY FEATURES

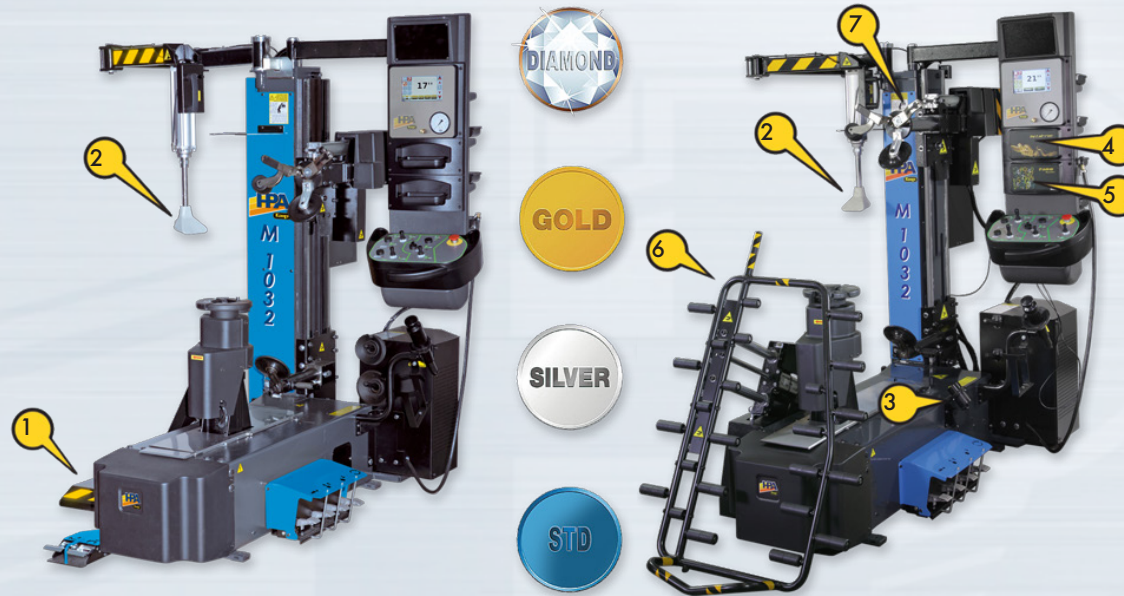

7. AUTOMATIC demounting cycle (see diagram below).

### ☐ Versions available

M 1032 Model	STD	STD A PL.	SILVER S.L.	SILVER P.L.	SILVER A PL.	GOLD S.L.	GOLD P.L.	DIAMOND A
1. Side wheel lifter	☑		☑			☑		
2. Bead presser	☑	☑	☑	☑	☑	☑	☑	☑
3. Video camera			☑	☑	☑	☑	☑	☑
4. Electronic inflator						☑	☑	☑
5. TPM-02 Reader								☑
6. Front wheel lifter		☑		☑	☑		☑	☑
7. Automatic cycle		☑			☑			☑

☑ : Supplied as standard.



# "LEVER-LESS" UNIVERSAL TYRE CHANGERS



## M 1028



**LEVER-LESS & Contact-Less**  
Technologies



- All models supplied with:
- 1 Complete universal locking pistol
  - 1 Set of plastic head protections
  - 1 Plastic bead clamp
  - 3 Plastic rim protections
  - 3 Short plastic rim protections
  - 1 Wheel centering cones set
  - 1 Brush for bead lubrication
  - 1 lubrication grease bucket support
  - 1 Operator's manual

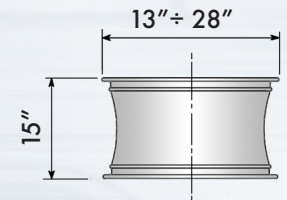

## M 1028

PN	Power supply	Description
0-11212012/25	200 - 230V/1Ph/50-60Hz	<b>M 1028 2V IP</b> with bead pressing tool
0-11212032/25	200 - 230V/1Ph/50-60Hz	<b>M 1028 2V IP</b> with bead pressing tool and wheel lifter
0-11212042/25	200 - 230V/1Ph/50-60Hz	<b>M 1028 2V IP FS</b> with bead pressing tool and wheel lifter



: New or Modified Item



# "LEVER-LESS" UNIVERSAL TYRE CHANGERS



## M 928 *Royal*

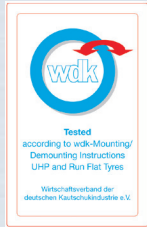

- All models supplied with:
- 1 Complete universal locking pistol
  - 1 Wheel centering cones set
  - 1 Pair of PPT plastic bead clamp
  - 3 Plastic rim protections
  - 3 Short plastic rim protections
  - 2 Bead protection plastic lever
  - 1 Set of plastic inserts for tool head
  - 1 Brush for bead lubrication
  - 1 Operator's manual

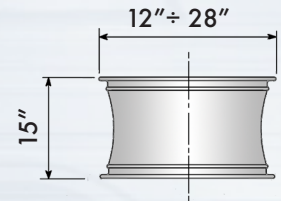

## M 928 ROYAL

PN	Power supply	Description
0-11106752/25	230V/1Ph/50-60Hz	<b>M 928 Royal + KWL28 wheel lifter</b> - "IP" system (Increased Power System)
0-11106762/25	230V/1Ph/50-60Hz	<b>M 928 Royal without KWL28</b> - "IP" system (Increased Power System)



: New or Modified Item

# "LEVER-LESS" UNIVERSAL TYRE CHANGERS



## M 830 LL

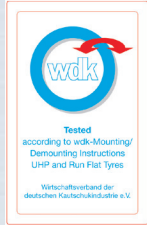

- All models supplied with:
- 1 Complete universal locking pistol
  - 1 Wheel centering cones set
  - 1 Pair of PPT plastic bead clamp
  - 3 Plastic rim protections
  - 3 Short plastic rim protections
  - 2 Bead protection plastic lever
  - 1 Set of plastic inserts for tool head
  - 1 Brush for bead lubrication
  - 1 Operator's manual

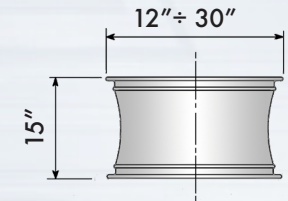

## M 830 LL

PN	Power supply	Description
0-15200112/25	230V/1Ph/50-60Hz	<b>M 830 LL + KFS 30 + KWL 30</b> - "IP" system (Increased Power System)
0-15200132/25	230V/1Ph/50-60Hz	<b>M 830 LL + KWL 30</b> - "IP" system (Increased Power System)
0-15200102/25	230V/1Ph/50-60Hz	<b>M 830 LL</b> - "IP" system (Increased Power System)



: New or Modified Item



# "LEVER-LESS" UNIVERSAL TYRE CHANGERS



## M 830 M

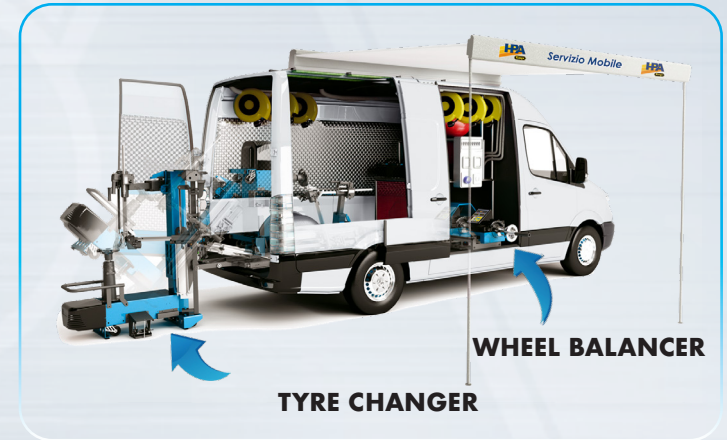
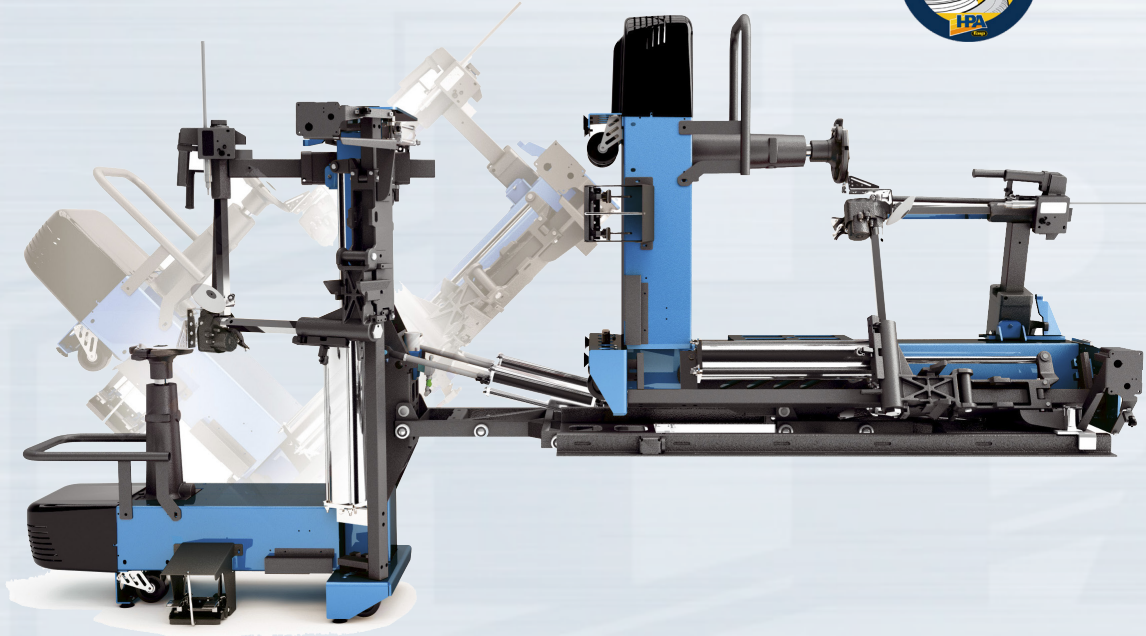

- All models supplied with:
- 1 Complete universal locking pistol
  - 1 Wheel centering cones set
  - 1 Pair of PPT plastic bead clamp
  - 3 Plastic rim protections
  - 3 Short plastic rim protections
  - 2 Bead protection plastic lever
  - 1 Set of plastic inserts for tool head
  - 1 Brush for bead lubrication
  - 1 Operator's manual

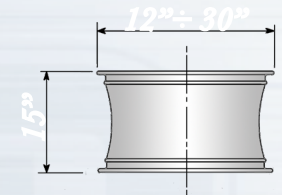

## M 830 M





PN	Power supply	Description
0-15200162/25	230V/1Ph/50-60Hz	<b>M 830 M - MOBILE SERVICE</b> (Tilting-back slide included)
8-51100038		<b>Power Unit Kit</b> (Complete electric and pneumatic components for the van trimmings: battery pack + battery charger, inverter, air reservoir, rotary compressor, cables, etc.).





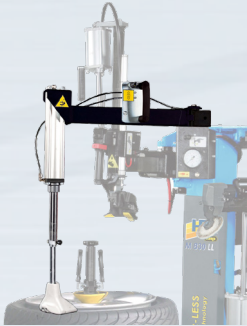

: New or Modified Item









# OPTIONAL ACCESSORIES FOR "LEVER-LESS" UNIVERSAL TYRE CHANGERS

PN	Picture	Description	M 1032	M 1028	M 928 ROYAL	M 830 LL	M 830 M
8-11100456		<b>MAT TC</b> Mobile Accessories Trolley	●	●	●	●	●
8-11100128		 <b>PH 28</b> Adjustable bead pressing arm			●		
8-11100097		 <b>PH 30</b> Adjustable bead pressing arm.				●	

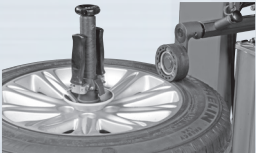
# OPTIONAL ACCESSORIES FOR "LEVER-LESS" UNIVERSAL TYRE CHANGERS

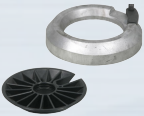





PN	Picture	Description	M 1032	M 1028	M 928 ROYAL	M 830 LL	M 830 M
8-11100404		<b>KFS 32</b> Tubeless inflating device.	●				
8-15100038		<b>ASME</b> tubeless inflating device (for USA and Canada only)	●				
8-11120053		<b>Quick inflating</b> system device		●			
8-11120054		<b>ASME</b> tubeless inflating device (for USA and Canada only)		●			
8-11100160		<b>KFS 28</b> Tubeless inflating device.			●		
8-11300041		<b>KFS 28</b> Tubeless inflating device (for USA and Canada only)			●		
8-11100111		<b>KFS 30</b> Tubeless inflating device.				●	
8-11100085		<b>KWL 30</b> Pneumatic wheel lifter device.				●	
8-11100159		<b>SA 28</b> Accessory holder support.			●		
8-11100287		<b>AUTOLOCK II</b> Electric rim clamping and releasing handle.			●	●	●

# OPTIONAL ACCESSORIES FOR "LEVER-LESS" UNIVERSAL TYRE CHANGERS





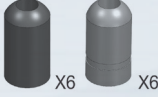

PN	Picture	Description	M 1032	M 1028	M 928 ROYAL	M 830 LL	M 830 M
8-11100338		<b>PAX</b> System kit		●	●	●	●
8-11100412		<b>KPBA</b> Automatic locking protection kit.	■				
8-11100400		<b>KPBM</b> Manual locking protection kit.			■	■	■
8-11100037		<b>Kit</b> for light commercial vehicles and pick-up rims. Rim hole diameter: max 158 mm	●	●			
8-11100086		<b>Kit</b> for light commercial vehicles and pick-up rims. Rim hole diameter: max 158 mm			●	●	●
8-15100003		<b>Special adapter</b> kit for wide rims (H=28mm). Es. Porsche rear wheel	●	●			
8-15100040		<b>H= 22mm spacer ring</b> To be combined with P/N 8-11100037 / 8-11100086 / 8-15100003	●	●	●	●	●
8-11100039		<b>FCR 28</b> Reverse wheel flange (maximum wheelbase 183 mm). Extensions H=100 mm	●	●	●	●	●
8-11100087		<b>FU 28</b> Universal flange for closed centre and special rims.	●		●	●	●









# OPTIONAL ACCESSORIES FOR "LEVER-LESS" UNIVERSAL TYRE CHANGERS

PN	Picture	Description	M 1032	M 1028	M 928 ROYAL	M 830 LL	M 830 M
8-11100046		<b>Extension kit</b> for reverse wheel flange, flange for close centre rims and non standard wheel kit. H + 23 mm / Diam. 25 mm	●	●	●	●	●
8-11100244		<b>KE 20 Set</b> of 6 "SHORT" extensions H = 80 mm	●	●	●	●	●
8-11100245		<b>KE 40 Set</b> of 6 "EXTRA SHORT" extensions H = 60 mm	●	●	●	●	●
8-11100246		<b>KE 25 Set</b> of 6 "LONG" extensions H = 125 mm	●	●	●	●	●
8-11100284		<b>KPC 12 Set</b> of 12 plastic protective caps.	●	●	●	●	●
8-11100291		<b>KEA 28 Set</b> of 6 spherical ext. for new AUDI wheels for flange FCR 28.	●	●	●	●	●
8-11100110	  <input type="checkbox"/> = Close centre rim kit <input type="checkbox"/> = Reverse rim kit	<b>FCS 32</b> Not standard rim kit.	●		●	●	●

# OPTIONAL ACCESSORIES FOR "LEVER-LESS" UNIVERSAL TYRE CHANGERS

PN	Picture	Description	M 1032	M 1028	M 928 ROYAL	M 830 LL	M 830 M
8-11100038		<b>Universal flange</b> for special and closed centre rims		●			
8-11200002		<b>Kit electro-mechanic</b> locking BMW	●				
8-15100024		<b>Kit pneumatic</b> locking BMW		●			
8-15100025		<b>Kit manual</b> locking BMW			●	●	●
8-15100026		<b>Spacer</b> H=64mm for vans (Daily)	●				
801262417		<b>PPT</b> Bead clamp for "Run Flat" tyres - WDK Approved.	■	■	■	■	■
801435685		<b>UPT</b> Universal bead clamp.		●			

# OPTIONAL ACCESSORIES FOR "LEVER-LESS" UNIVERSAL TYRE CHANGERS

PN	Picture	Description	M 1032	M 1028	M 928 ROYAL	M 830 LL	M 830 M
8-11100120		Sliding bead <b>pressing device</b> .		●			
8-11120013		<b>PTS</b> Bead protection plastic lever.	■	■	■	■	■
8-11120014		<b>REP-3 Kit</b> of 3 plastic rim protections.	■	■	■	■	■
8-11120015		<b>REP-3S Kit</b> of 3 short plastic rim protections.	■	■	■	■	■
8-11400293		<b>KPP-LL Kit</b> of plastic inserts for "LEVER-LESS" tool head. Suitable for tyre changer with serial number up to: FMG143250			■	■	■
8-11400325		<b>KPP-LL V3 Kit</b> of plastic inserts for "LEVER-LESS" tool head. Suitable for tyre changer with serial number starting from: FMG143251			■	■	■



# OPTIONAL ACCESSORIES FOR "LEVER-LESS" UNIVERSAL TYRE CHANGERS

PN	Picture	Description	M 1032	M 1028	M 928 ROYAL	M 830 LL	M 830 M
8-11100401	<p>x2 x2 x3 x5</p>	<b>Protections kit</b> for automatic locking		■			
8-11120058	<p>x5</p>	<b>Kit of 5</b> protections for cones ø 145 mm		●			
8-11120083		<b>Retractable lever kit</b> (1 pc for each item)	●	●			
8-11100125		<b>DRT Template</b> for "LEVER-LESS" tool head adjustment.			●	●	●
8-11120035	<p>x3</p>	<b>KPUL</b> Spare tool plastic protection kit	●	●			
8-11120036	<p>x5 x5 x7</p>	<b>TH</b> Spare tool plastic protection kit	●	●			

# OPTIONAL ACCESSORIES FOR "LEVER-LESS" UNIVERSAL TYRE CHANGERS

## COMPLEMENTARY DEVICES

PN	Picture	Description	M 1032	M 1028	M 928 ROYAL	M 830 LL	M 830 M
6015001300		<b>TPM-02</b> TPMS Diagnostic Tool	●	●	●	●	●
8-64500013		<b>OBD Kit</b>	●	●	●	●	●
6015001391		<b>TPM-02 Plus</b> TPM-02 + OBD kit.	●	●	●	●	●
6015001360		<b>TPM-02</b> Bluetooth printer.	●	●	●	●	●

# OPTIONAL ACCESSORIES FOR "LEVER-LESS" UNIVERSAL TYRE CHANGERS

## COMPLEMENTARY DEVICES

PN	Picture	Description	M 1032	M 1028	M 928 ROYAL	M 830 LL	M 830 M
8-51100029		<b>TPM-02</b> standard annual subscription.	●	●	●	●	●
8-51120003		<b>TPM-02</b> extended annual subscription.	●	●	●	●	●
8-51120001		<b>TPM-02 + E OBD</b> annual subscription.	●	●	●	●	●
8-51120004		<b>TPM-02 + E OBD</b> extended annual subscription.	●	●	●	●	●



# "LEVER-LESS" PASSENGER CAR TYRE CHANGERS



## M 824 LL series

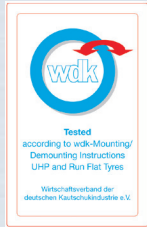

- All models supplied with:
- 1 Plastic cover for bead breaker blade
  - 1 Set of 4 jaw pads for alloy rims
  - 1 PPT plastic bead clamp
  - 3 Plastic rim protections
  - 3 Short plastic rim protections
  - 2 Bead protection plastic lever
  - 1 Set of plastic inserts for tools head
  - 1 Brush for bead lubrication
  - 1 Operator's manual



### M 824 LL

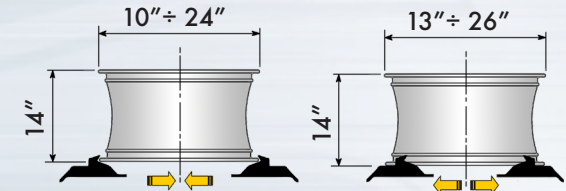

PN	Power supply	Description
0-11110422/25	230V/1Ph/50-60Hz	<b>M 824 2V FS LL + ALLY 90</b> - "IP" system (Increased Power System)
0-11110522/25	230V/1Ph/50-60Hz	<b>M 824 2V LL + ALLY 90</b> - "IP" system (Increased Power System)
0-11110402/25	230V/1Ph/50Hz	<b>M 824 FS LL + ALLY 90</b>
0-11110501/25	400V/3Ph/50Hz	<b>M 824 LL + ALLY 90</b>
0-11110412/25	230V/1Ph/60Hz	<b>M 824 FS LL + ALLY 90</b>



: New or Modified Item







PN	Power supply	Description
0-11110512/25	230V/1Ph/60Hz	<b>M 824 LL + ALLY 90.</b>
0-11110482/25	230V/1Ph/50-60Hz	<b>M 824 2V FS LL</b>
0-11110542/25	230V/1Ph/50-60Hz	<b>M 824 2V LL</b>
0-11110472/25	230V/1Ph/50Hz	<b>M 824 FS LL</b>
0-11110492/25	230V/1Ph/60Hz	<b>M 824 FS LL</b>
0-11110521/25	400V/3Ph/50Hz	<b>M 824 LL</b>

## OPTIONAL ACCESSORIES FOR M 824 LL

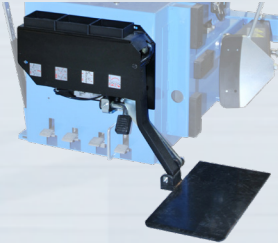
PN	Picture	Description	
8-11100451		<b>ALLY 85</b> Multipurpose bead lifting / pressing device. RH side. Disc version	
8-11100343		<b>ALLY 30</b> Bead lifting/pressing multipurpose device	
8-11120019		<b>ALLY 30</b> Customization and installation kit for M824 - M724S	
8-11400058		<b>EFS70/W</b> Electronic tyre inflating device for wall installation	
8-11100296		<b>DRT 24</b> Template for "LEVER-LESS" tool head adjustment	
801262417		<b>PPT</b> Bead clamp for "Run Flat" tyres - WDK Approved	



## OPTIONAL ACCESSORIES FOR M 824 LL

PN	Picture	Description
8-11100243		<b>KWL80</b> Pneumatic wheel lifter device. Capacity: 80 kg.
8-11100044		<b>PCL54 Set of 12</b> integral plastic jaws pads for protecting alloy rims
801258383		<b>GPS60 Set of 6</b> plastic covers for bead breaker blade
8-11120013		<b>PTS</b> Bead protection plastic lever
8-11120014		<b>REP-3 Kit of 3</b> plastic rim protections.
8-11120015		<b>REP-3S Kit of 3</b> short plastic rim protections.

## OPTIONAL ACCESSORIES FOR M 824 LL

PN	Picture	Description
8-11400293		<b>KPP-LL Kit</b> of plastic inserts for "LEVER-LESS" tool head. Suitable for tyre changer with serial number up to: FMG143250
8-11400325		<b>KPP-LL V3 Kit</b> of plastic inserts for "LEVER-LESS" tool head. Suitable for tyre changer with serial number starting from: FMG143251
8-11120095		<b>Lube bracket</b> 1-5 Kg
8-11120092		<b>Storage tray</b>
8-11100042		<b>GA69</b> Set of adapters for 8"÷9" rims.
8-11100041		<b>GA524</b> Set of adapters for increasing outside locking of 4" (alloy rims).
8-11100036		<b>GM520</b> Set of motorcycle wheel adapters from 15" to 23"/25"

# PASSENGER CAR TYRE CHANGERS

## M 724S series



**NEW!**



ALLY 85  
available on request

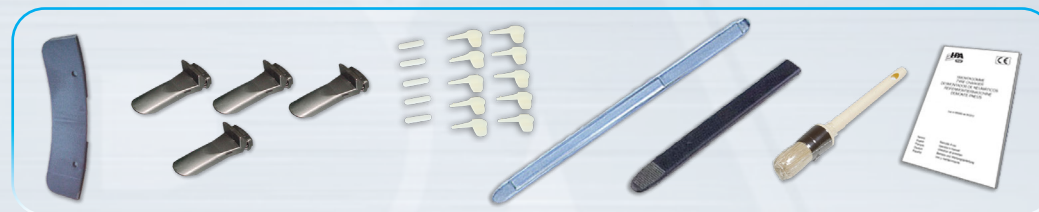

- All models supplied with:
- 1 Bead lever
  - 1 Set of 4 jaw pads for alloy rims (front/rear type)
  - 1 Plastic cover for bead breaker blade
  - 1 Plastic cover for bead lever
  - 1 Set of plastic inserts for tools head (Additional)
  - 1 Brush for bead lubrication 1 Operator's manual

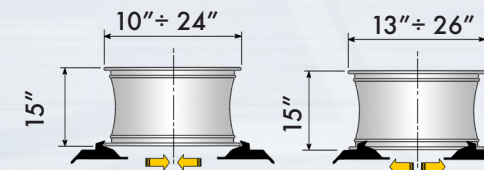

### M 724S

PN	Power supply	Description
0-11211302/25	200-230V/1Ph/50-60Hz	<b>M 724S 2V IP FS</b>
<b>NEW!</b> 0-11211303/25	200-230V/1Ph/50-60Hz	<b>M 724S 2V IP FS + ALLY85 + WDK</b>
0-11211301/25	400V/3Ph/50Hz	<b>M 724S FS</b>
0-11211312/25	200-230V/1Ph/50	<b>M 724S FS</b>
0-11211322/25	200-230V/1Ph/60	<b>M 724S FS</b>
0-11211202/25	200-230V/1Ph/50-60Hz	<b>M 724S 2V IP</b>
0-11211201/25	400V/3Ph/50Hz	<b>M 724S</b>
0-11211206/25	12 V	<b>M 724S</b>
<b>Versions with pneumatic tools positioning</b>		
0-11211502/25	200-230V/1Ph/ 50-60Hz	<b>M 724S AUTOMATIC 2V IP FS</b>
0-11211402/25	200-230V/1Ph/ 50-60Hz	<b>M 724S AUTOMATIC 2V IP</b>



: New or Modified Item



# PASSENGER CAR TYRE CHANGERS



## M 624 series



- All models supplied with:
- 1 Bead lever
  - 1 Set of 4 jaw pads for alloy rims (front/rear type)
  - 1 Plastic cover for bead breaker blade
  - 1 Plastic cover for bead lever
  - 1 Set of plastic inserts for tools head (Additional)
  - 1 Brush for bead lubrication
  - 1 Operator's manual

### M 624

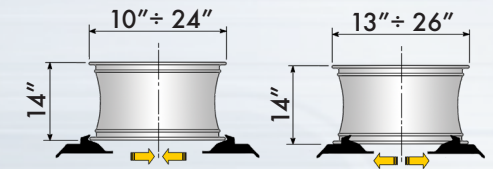

PN	Power supply	Description
0-11106322/25	230V/1Ph/50-60Hz	<b>M 624 2V FS</b> - "IP" system (Increased Power System)
0-11106301/25	400V/3Ph/50Hz	<b>M 624 FS</b>
0-11106302/25	230V/1Ph/50Hz	<b>M 624 FS</b>
0-11106401/25	400V/3Ph/50Hz	<b>M 624</b>



: New or Modified Item

# PASSENGER CAR TYRE CHANGERS

## M 522 series



- All models supplied with:
- 1 Bead lever
  - 1 Set of 4 jaw pads for alloy rims (front/rear type)
  - 1 Plastic cover for bead breaker blade
  - 1 Plastic cover for bead lever
  - 1 Set of plastic inserts for tools head (Additional)
  - 1 Brush for bead lubrication
  - 1 Operator's manual

### M 522

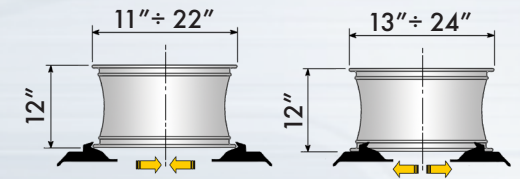

PN	Power supply	Description
0-11108441/25	400V/3Ph/50Hz	<b>M 522 2V FS</b>
0-11108432/25	230V/1Ph/50-60Hz	<b>M 522 2V FS</b> - "IP" system (Increased Power System)
0-11108451/25	230V/3Ph/60Hz	<b>M 522 2V FS</b>
0-11108401/25	400V/3Ph/50Hz	<b>M 522 FS</b>



: New or Modified Item

PN	Power supply	Description
0-11108402/25	230V/1Ph/50Hz	<b>M 522 FS</b>
0-11108411/25	200-230V/3Ph/50Hz	<b>M 522 FS</b>
0-11108421/25	200-230V/3Ph/60Hz	<b>M 522 FS</b>
0-11108412/25	200-230V/1Ph/60Hz	<b>M 522 FS</b>
0-11108341/25	400V/3Ph/50Hz	<b>M 522 2V</b>
0-11108332/25	230V/1Ph/50-60Hz	<b>M 522 2V</b> - "IP" system (Increased Power System)
0-11108301/25	400V/3Ph/50Hz	<b>M 522</b>
0-11108302/25	230V/1Ph/50Hz	<b>M 522</b>
0-11108312/25	230V/1Ph/60Hz	<b>M 522</b>



# PASSENGER CAR TYRE CHANGERS



## M 424 A series



- All models supplied with:
- 1 Bead lever
  - 1 Set of 4 jaw pads for alloy rims (front/rear type)
  - 1 Plastic cover for bead breaker blade
  - 1 Plastic cover for bead lever
  - 1 Set of plastic inserts for tools head (Additional)
  - 1 Brush for bead lubrication
  - 1 Operator's manual
  - 1 BAR/PSI inflating gun (\*)
- \*: Supplied for M 424 A 2V and M 424 A only.

### M 424 A

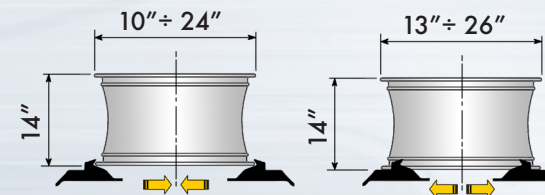

PN	Power supply	Description
0-11201641/25	400V/3Ph/50Hz	<b>M 424 A 2V FS</b>
0-11201632/25	200-230V/1Ph/50-60Hz	<b>M 424 A 2V FS</b> - "IP" system (Increased Power System)
0-11201651/25	200-230V/3Ph/60Hz	<b>M 424 A 2V FS</b>
0-11201601/25	400V/3Ph/50Hz	<b>M 424 A FS</b>



: New or Modified Item

PN	Power supply	Description
0-11201602/25	230V/1Ph/50Hz	<b>M 424 A FS</b>
0-11201541/25	400V/3Ph/50Hz	<b>M 424 A 2V</b>
0-11201551/25	200-230V/3Ph/60Hz	<b>M 424 A 2V</b>
0-11201532/25	200-230V/1Ph/50-60Hz	<b>M 424 A 2V</b> - "IP" system (Increased Power System)
0-11201501/25	400V/3Ph/50Hz	<b>M 424 A</b>
0-11201502/25	230V/1Ph/50Hz	<b>M 424 A</b>

# PASSENGER CAR TYRE CHANGERS



## M 424 series



**NEW!**



- All models supplied with:
- 1 Bead lever
  - 1 Set of 4 jaw pads for alloy rims (front/rear type)
  - 1 Plastic cover for bead breaker blade
  - 1 Plastic cover for bead lever
  - 1 Set of plastic inserts for tools head (Additional)
  - 1 Brush for bead lubrication
  - 1 Operator's manual
  - 1 BAR/PSI Inflating gun (\*)
- \*: Supplied for M 424 2V and M 424 models only.

### M 424

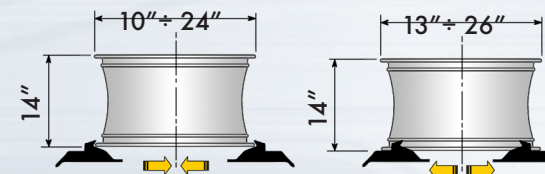

PN	Power supply	Description
0-11200841/25	400V/3Ph/50Hz	<b>M 424 2V FS</b>
0-11200832/25	230V/1Ph/50-60Hz	<b>M 424 2V FS</b> - "IP" system (Increased Power System)
<b>NEW!</b> 0-11200853/25	200-230V/1Ph/50-60Hz	<b>M 424 2V FS IP + ALLY85 + WDK</b>
0-11200851/25	200-230V/3Ph/60Hz	<b>M 424 2V FS</b>
0-11200801/25	400V/3Ph/50Hz	<b>M 424 FS</b>



  : New or Modified Item



PN	Power supply	Description
0-11200802/25	230V/1Ph/50Hz	<b>M 424 FS</b>
0-11200812/25	230V/1Ph/60Hz	<b>M 424 FS</b>
0-11200811/25	200-230V/3Ph/60Hz	<b>M 424 FS</b>
0-11200741/25	400V/3Ph/50Hz	<b>M 424 2V</b>
0-11200751/25	200-230V/3Ph/60Hz	<b>M 424 2V</b>
0-11200732/25	230V/1Ph/50-60Hz	<b>M 424 2V</b> - "IP" system (Increased Power System)
0-11200701/25	400V/3Ph/50Hz	<b>M 424</b>
0-11200702/25	200-230V/1Ph/50Hz	<b>M 424</b>
0-11200712/25	200-230V/1Ph/60Hz	<b>M 424</b>
0-11200711/25	200-230V/3Ph/60Hz	<b>M 424</b>

# PASSENGER CAR TYRE CHANGERS



## M 422 series



- All models supplied with:
- 1 Bead lever
  - 1 Set of plastic inserts for tools head (Additional)
  - 1 Brush for bead lubrication
  - 1 Operator's manual
  - 1 BAR/PSI Inflating gun (\*)
- \*: Supplied for M 422 2V and M 422 models only.

### M 422

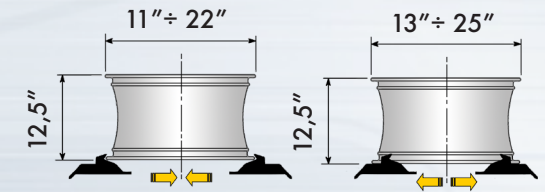

PN	Power supply	Description
0-11210941/25	400V/3Ph/50Hz	<b>M 422 2V FS</b>
0-11210901/25	400V/3Ph/50Hz	<b>M 422 FS</b>
0-11211041/25	400V/3Ph/50Hz	<b>M 422 2V</b>
0-11211001/25	400V/3Ph/50Hz	<b>M 422</b>



  : New or Modified Item

# PASSENGER CAR TYRE CHANGERS

PN	Power supply	Description
0-11210932/25	230V/1Ph/50-60Hz	<b>M 422 2V FS</b> - "IP" system (Increased Power System)
0-11210951/25	200-230V/3Ph/60Hz	<b>M 422 2V FS</b>
0-11210971/25	400V/3Ph/50Hz	<b>M 422 2V FS BAR</b>
0-11210902/25	230V/1Ph/50Hz	<b>M 422 FS</b>
0-11210912/25	230V/1Ph/60Hz	<b>M 422 FS</b>
0-11210911/25	200-230V/3Ph/60Hz	<b>M 422 FS</b>
0-11210961/25	400V/3Ph/50Hz	<b>M 422 FS BAR</b>
0-11211051/25	200-230V/3Ph/60Hz	<b>M 422 2V</b>
0-11211032/25	230V/1Ph/50-60Hz	<b>M 422 2V</b> - "IP" system (Increased Power System)
0-11211002/25	200-230V/1Ph/50Hz	<b>M 422</b>
0-11211012/25	230V/1Ph/60Hz	<b>M 422</b>
0-11211011/25	200-230V/3Ph/60Hz	<b>M 422</b>



# PASSENGER CAR TYRE CHANGERS



## M 322 FS - M 322



- All models supplied with:
- 1 Bead lever
  - 1 Set of plastic inserts for tools head (Additional)
  - 1 Brush for bead lubrication
  - 1 Operator's manual
  - 1 BAR/PSI Inflating gun (\*)
- \*: Supplied for M 322 models only.

### M 322 FS - M 322

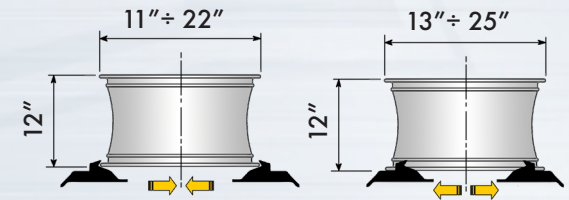

PN	Power supply	Description	
0-11201001/25	400V/3Ph/50Hz	<b>M 322 FS</b>	
0-11201002/25	200-230V/1Ph/50Hz	<b>M 322 FS</b>	
0-11200901/25	400V/3Ph/50Hz	<b>M 322</b>	
0-11200902/25	200-230V/1Ph/50Hz	<b>M 322</b>	
0-11200912/25	200-230V/1Ph/60Hz	<b>M 322</b>	
0-11200906/25	12 V	<b>M 322</b>	



: New or Modified Item

# OPTIONAL ACCESSORIES FOR PASSENGER CAR TYRE CHANGERS

## COMPLEMENTARY DEVICES

PN	Picture	Description
6015001300		<b>TPM-02</b> TPMS Diagnostic Tool.
8-64500013		<b>OBD Kit</b>
6015001391		<b>TPM-02 Plus</b> TPM-02 + OBD kit.
6015001360		<b>TPM-02</b> Bluetooth printer.

## OPTIONAL ACCESSORIES FOR PASSENGER CAR TYRE CHANGERS

### COMPLEMENTARY DEVICES



PN	Picture	Description
8-51100029		<b>TPM-02</b> standard annual subscription.
8-51120003		<b>TPM-02</b> extended annual subscription.
8-51120001		<b>TPM-02</b> + EOBD annual subscription.
8-51120004		<b>TPM-02</b> + EOBD extended annual subscription.



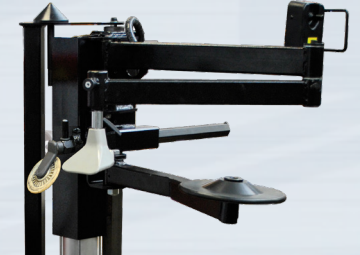





# OPTIONAL ACCESSORIES FOR PASSENGER CAR TYRE CHANGERS

PN	Picture	Description	M 724S series	M 624 series	M 522 series	M 424 series	M 422 series	M 322 series	M 322 Bike
8-11400211		<b>ALLY 80</b> Universal bead lifting / pressing device.		●	●				
8-11100451		<b>ALLY 85</b> Multipurpose bead lifting / pressing device.	●						
8-11200003		<b>ALLY 85</b> Multipurpose bead lifting / pressing device.				●			

# OPTIONAL ACCESSORIES FOR PASSENGER CAR TYRE CHANGERS

PN	Picture	Description	M 724S series	M 624 series	M 522 series	M 424 series	M 422 series	M 322 series	M 322 Bike
8-11100153		<b>Extension</b> for bead pressing cone				●	●		
8-11100343		<b>ALLY 30</b> Bead lifting/pressing multipurpose device.	●	●	●	●	●		
8-11100363		<b>ALLY 30</b> Customization and installation kit for M624/M522 series		●	●				
8-11200004		<b>ALLY 30</b> Customization and installation kit for M 424 series				●			
8-11220006		<b>ALLY 30</b> Customization and installation kit for M 422 series					●		
8-11120019		<b>ALLY 30</b> Customization and installation kit for M824 - M724S		●					
8-11120032		<b>BPL</b> Bead pressing device with one tool arm. LH side installation.					●	●	●

# OPTIONAL ACCESSORIES FOR PASSENGER CAR TYRE CHANGERS

PN	Picture	Description	M 724S series	M 624 series	M 522 series	M 424 series	M 422 series	M 322 series	M 322 Bike
801276833		<b>PGM</b> Michelin tyre inflating gun BAR scale - EC Homologated.			●				
801281796		<b>PGE</b> Economic tyre inflating gun BAR scale - EC Homologated.			●				
801281797		<b>PGM2</b> Michelin tyre inflating gun with BAR / PSI scales.			●				
801271621		<b>PGE2</b> Economic tyre inflating gun with both BAR and PSI scales.			●				
8-51120007		<b>ASTURO</b> BAR/PSI inflating gun				●			
8-11400058		<b>EFS70/W</b> Electronic tyre inflating device for wall installation	●	●	●	●	●		







# OPTIONAL ACCESSORIES FOR PASSENGER CAR TYRE CHANGERS

PN	Picture	Description	M 724S series	M 624 series	M 522 series	M 424 series	M 422 series	M 322 series	M 322 Bike
8-11100243		<b>KWL80</b> Pneumatic wheel lifter device. Capacity: 80 kg.	●	●	●				
8-11220007		<b>KWL60</b> Pneumatic wheel lifter device. Capacity: 60 kg.				●	●	●	●
801262417		<b>PPT</b> Bead clamp for "Run Flat" tyres - WDK Approved.	●	●	●	●	●	●	●
801435685		<b>UPT</b> Universal bead clamp.	●	●	●	●	●	●	●
8-11100120		Sliding bead <b>pressing device</b> .	●	●	●	●	●	●	●





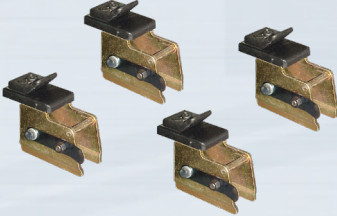



 : New or Modified Item

# OPTIONAL ACCESSORIES FOR PASSENGER CAR TYRE CHANGERS

PN	Picture	Description	M 724S series	M 624 series	M 522 series	M 424 series	M 422 series	M 322 series	M 322 Bike
8-11400290		<b>PTR</b> Roller bead pressing device for “Run Flat” and UHP tyres.	●	●	●	●	●	●	●
8-11100042		<b>GA69</b> Set of adapters for 8”÷9” rims.	●	●	●	●	●	●	
8-11100041		<b>GA524</b> Set of adapters for increasing outside locking of 4” (alloy rims).	●	●	●	●	●	●	
8-11100036		<b>GM520</b> Set of motorcycle wheel adapters from 15” to 23”/25”	●	●	●	●	●	●	
8-11120027		<b>Special bead breaker blade</b> for motorcycle wheels.	●	●	●	●	●	●	

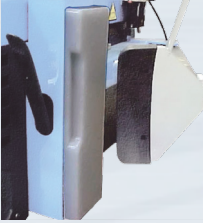
# OPTIONAL ACCESSORIES FOR PASSENGER CAR TYRE CHANGERS





PN	Picture	Description	M 724S series	M 624 series	M 522 series	M 424 series	M 422 series	M 322 series	M 322 Bike
8-11100044		<b>PCL54 Set of 12</b> integral plastic jaws pads for protecting alloy rims.	●	■	■	■	●	●	
063905800		<b>PPC</b> Plastic protections for clamps (20 pcs)	●	●	●	●	●	●	
801254341		<b>PS10 Set of 10</b> special plastic inserts for tool head.		■	■	■	■	■	■
801258898		<b>PTH5 Set of 5</b> special plastic pads for tool head		■	■	■	■	■	■
801458663		<b>PTS60</b> Plastic cover for side bead breaker					●	●	●
801258383		<b>GPS60 Set of 6</b> plastic covers for bead breaker blade	●	■	■	■	●	●	



# OPTIONAL ACCESSORIES FOR PASSENGER CAR TYRE CHANGERS

PN	Picture	Description	M 724S series	M 624 series	M 522 series	M 424 series	M 422 series	M 322 series	M 322 Bike
801246241		<b>KGL6 Kit of 6</b> plastic covers for tyre lever to protect alloy rims.	■	■	■	■	●	●	●
8-11120050		<b>TAM/WING</b> Steel tool head for cars and motorcycles (starting from serial # FRD267085)	■			●	●	●	●
8-11100369		<b>MPK5</b> Set of 10+10 plastic inserts for TAM/WING tool head	●			●	●	●	●
801250309		<b>TCL40</b> Plastic tool head		●	●				
8-11400329		<b>TPA/WING</b> Full assembly plastic tool-head kit with adapter (starting from serial #FRD267085)	●			●	●	●	●
8-11400334		<b>TPA/WING</b> Full assembly plastic tool-head kit with adapter (before serial #FRD267085) For M 522 and M 624 always installable.	●	●	●	●	●	●	●
8-11400330		<b>TPA-Wing</b> single plastic tool-head	●			●	●	●	●

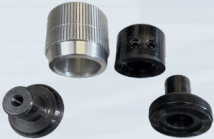
# OPTIONAL ACCESSORIES FOR PASSENGER CAR TYRE CHANGERS

PN	Picture	Description	M 724S series	M 624 series	M 522 series	M 424 series	M 422 series	M 322 series	M 322 Bike
8-11100378		<b>TMN Mounting/demounting</b> tool head for scooter wheels. Complete with plastic alloy rim protections (starting from serial #FRD267085)	●			●	●	●	●
8-11100370	IMAGE NOT AVAILABLE	<b>MPK6 Protection kit</b> for new scooters m/d head (for TMN scooter)	●			●	●	●	●
801252083		<b>Scooter m/d head tool</b> for 8" rims (up to serial #FRD267084)		●	●				
8-11100001		<b>M/D head tool fast fitting kit</b> (up to serial #FRD267084)		●	●				
8-11120089		<b>Kit quick change tool head</b> (starting from serial # FRD267085)	●			●	●	●	●
8-11120014		<b>REP-3 Kit of 3 plastic rim protections</b>	●	●	●	●	●	●	●
8-11120015		<b>REP-3S Kit of 3 short plastic rim protections</b>	●	●	●	●	●	●	●

# OPTIONAL ACCESSORIES FOR PASSENGER CAR TYRE CHANGERS

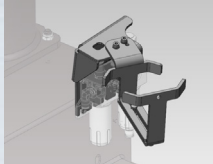
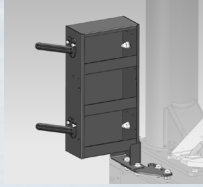
PN	Picture	Description	M 724S series	M 624 series	M 522 series	M 424 series	M 422 series	M 322 series	M 322 Bike
8-11120028/90		PWR Roller board for bead breaker. To fix to the floor.	●	●	●	●	●	●	●
8-11120095		Lube bracket 1-5 Kg	●	●	●	●		●	●
8-11120092		Storage tray	●			●	●	●	●



# MOTORCYCLE TYRE CHANGERS



## M 322 BIKE



- All models supplied with:
- 1 Bead lever
  - 1 Set of plastic inserts for tools head (Additional)
  - 1 Brush for bead lubrication
  - 1 Operator's manual
  - 1 BAR/PSI Inflating gun (\*)
- \*: Supplied for M 322 models only.

## M 322 BIKE

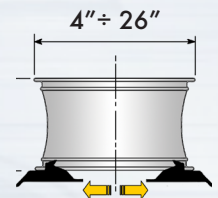

PN	Power supply	Description
0-11211601/25	400V/3Ph/50Hz	<b>M 322 BIKE</b>
0-11211602/25	230V/3Ph/50Hz	<b>M 322 BIKE</b>
0-11211603/25	230V/1Ph/50Hz	<b>M 322 BIKE</b>
0-11211604/25	230V/1Ph/60Hz	<b>M 322 BIKE</b>
0-11211605/25	115V/1Ph/60Hz	<b>M 322 BIKE</b>



: New or Modified Item

## OPTIONAL ACCESSORIES FOR M 322 BIKE

PN	Picture	Description
8-11100461		<b>Racing bike turntable</b> jaw kit 8" - 26"
8-11100462		<b>ATV turntable</b> jaw kit 5"-18"
8-11100463		<b>Removable platform</b> for bike wheels

**MORE ACCESSORIES FOR MODEL M 322 BIKE ARE AVAILABLE IN THE CAR TYRE CHANGER ACCESSORIES SECTION**

# MOTORCYCLE TYRE CHANGERS



## M 200 BIKE



- All models supplied with:
- 1 Bead lever
  - 1 Plastic cover for bead lever
  - 1 Plastic cover for bead breaker blade
  - 1 Set of 4 plastic adapters for go-kart wheels
  - 1 Set of plastic inserts for tools head (Additional)
  - 1 Brush for bead lubrication
  - 1 BAR/PSI Inflating gun
  - 1 Operator's manual

### M 200 BIKE

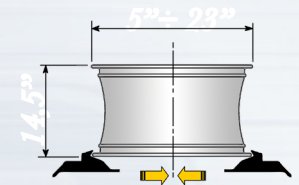

PN	Power supply	Description
0-11613401/25	230V/1Ph/50Hz	<b>M 200 BIKE</b>
0-11613405/25	400V/3Ph/50Hz	<b>M 200 BIKE</b>
0-11613414/25	115V/1Ph/60Hz	<b>M 200 BIKE</b>



: New or Modified Item



## OPTIONAL ACCESSORIES FOR M 200 BIKE

PN	Picture	Description
8-11600020		<b>PPM</b> Set of 6 plastic covers for bead breaker blade.
8-11600116		<b>SR</b> Wheel holder arm set.
8-11600117		<b>PR</b> Roller for fitting wheels smaller than 8"
8-11600118		<b>UCA Set of 4</b> adapters for cross wheels.
8-11600119		<b>ATV A Set of 4</b> adapters for ATV wheels (From 6" to 16")
8-11600120		<b>ATV C</b> Centering cone for ATV wheels (only with SR wheel holder arm).

## OPTIONAL ACCESSORIES FOR M 200 BIKE

PN	Picture	Description
8-11600121		<b>CKM Set of 4</b> clamping jaws
8-11600122		<b>GKS Set</b> of plastic covers
8-11600123		<b>GK Set of 4</b> adapters for go-kart wheels
8-11600124		<b>PO</b> Tray
8-11600125		<b>TG1</b> 1 kg. lubrication grease bucket
8-11600126		<b>IG</b> Tyre inflating gun with BAR scale on pressure gauge. EC Homologated

# HEAVY-DUTY TYRE CHANGERS



## F 565



Stand by

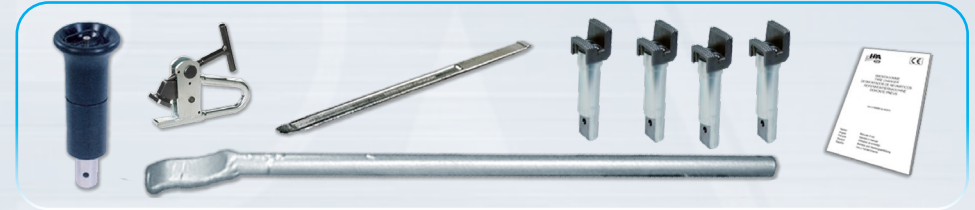

- Supplied with:
- 1 60" jaw set (4 pcs.)
  - 1 Roller for tubeless
  - 1 Bead lifting lever
  - 1 Rim ring lever
  - 1 Rim clamp
  - 1 Operator's manual

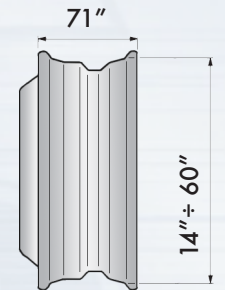

## F 565

PN	Power supply	Description
0-12455001/25	400V/3Ph/50Hz	<b>F 565</b>
0-12455002/25	230V/3Ph/60Hz	<b>F 565</b>
0-12455003/25	400V/3Ph/60Hz	<b>F 565</b>



: New or Modified Item



# HEAVY-DUTY TYRE CHANGERS



## F 562

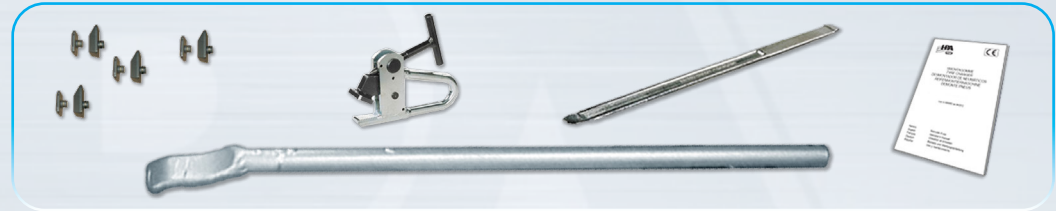

- Supplied with:
- 1 Bead lifting lever
  - 1 Rim ring lever
  - 1 Rim clamp
  - 1 Set of 4+4 special plastic inserts for jaw
  - 1 Operator's manual

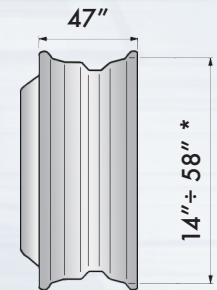

\*: with PA4V extensions

## F 562

PN	Power supply	Description
0-12440126/25	400V/3Ph/50Hz	<b>F 562</b>
0-12440128/25	230V/3Ph/50Hz	<b>F 562</b>



: New or Modified Item

# HEAVY-DUTY TYRE CHANGERS



## F 562 M

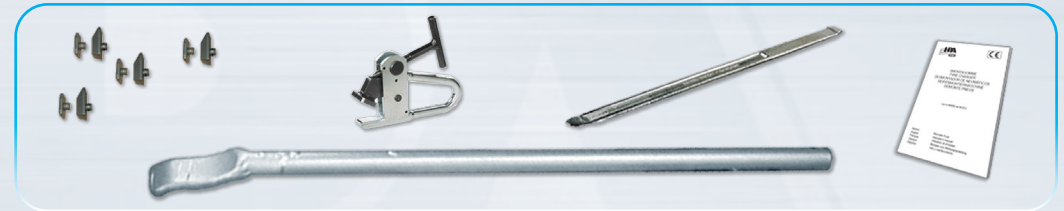
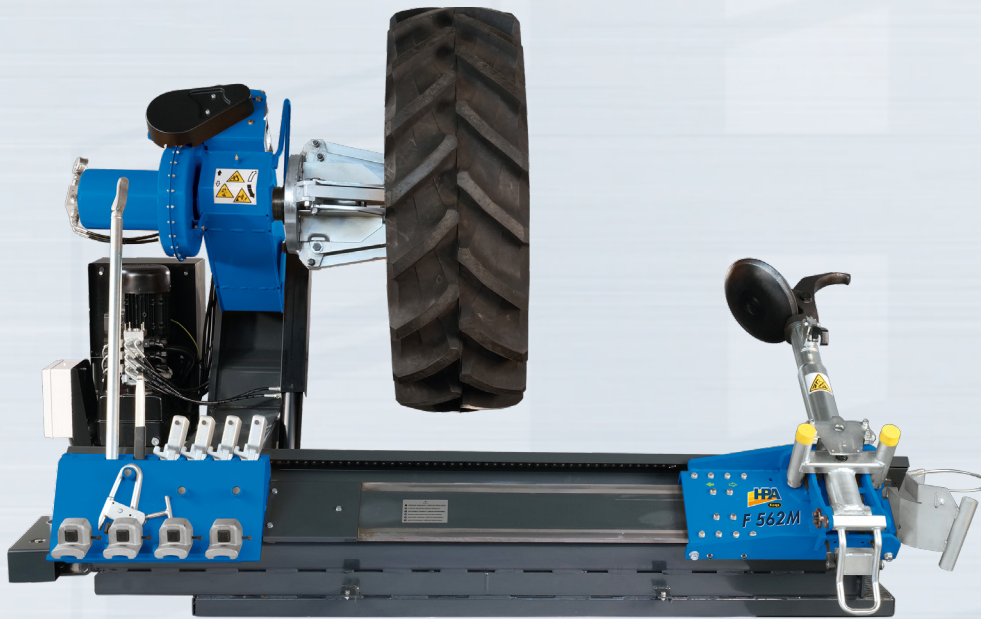

- Supplied with:
- 1 Bead lifting lever
  - 1 Rim ring lever
  - 1 Rim clamp
  - 1 Set of 4+4 special plastic inserts for jaw
  - 1 Operator's manual

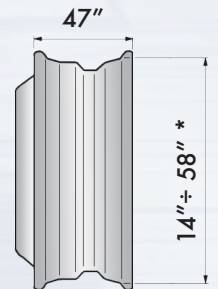

\*: with PA4V extensions

## F 562 M

PN	Power supply	Description
0-12400701/25	400V/3Ph/50Hz	<b>F 562 M</b>



: New or Modified Item



# HEAVY-DUTY TYRE CHANGERS



## F 560 A Special F 560 Special

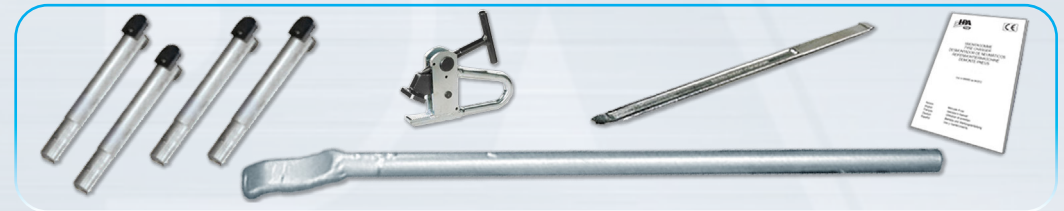

- Supplied with:
- 1 Extensions kit 56" (4 pcs)
  - 1 Bead lifting lever
  - 1 Rim ring lever
  - 1 Rim clamp
  - 1 Operator's manual

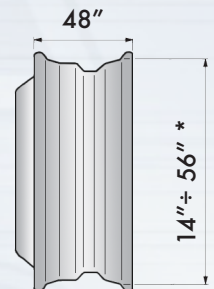

\*: with KP56 extensions

### F 560 - F 560 A SPECIAL

PN	Power supply	Description
0-12453005/25	400V/3Ph/50Hz	<b>F 560 A SPECIAL</b>
0-12453006/25	230V/3Ph/60Hz	<b>F 560 A SPECIAL</b>
0-12453001/25	400V/3Ph/50Hz	<b>F 560 SPECIAL</b>
0-12453002/25	230V/3Ph/60Hz	<b>F 560 SPECIAL</b>



: New or Modified Item



# HEAVY-DUTY TYRE CHANGERS



## F 560 A Special Y F 560 Special Y

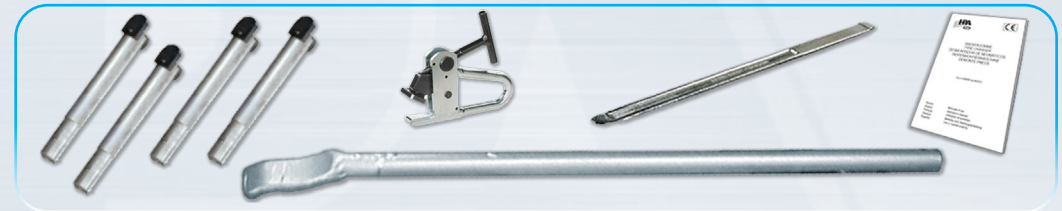
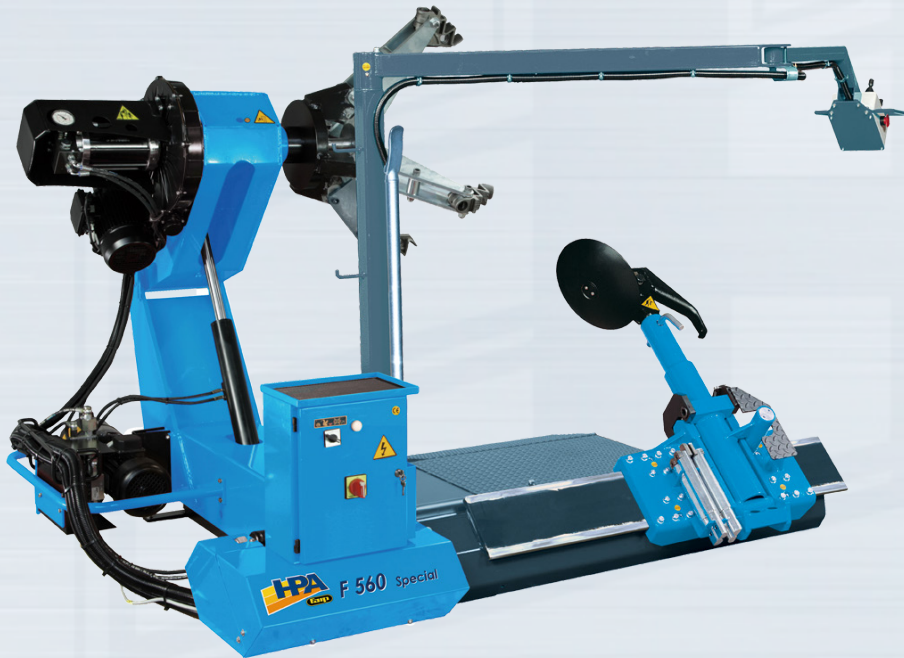

- Supplied with:
- 1 Extensions kit 56" (4 pcs)
  - 1 Bead lifting lever
  - 1 Rim ring lever
  - 1 Rim clamp
  - 1 Operator's manual

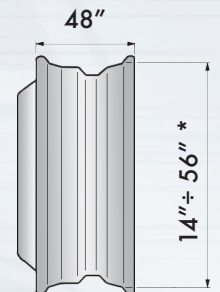

\*: with KP56 extensions

### F 560 - F 560 A SPECIAL Y

PN	Power supply	Description
0-12453007/25	400V/3Ph/50Hz	<b>F 560 A SPECIAL Y</b>
0-12453008/25	230V/3Ph/60Hz	<b>F 560 A SPECIAL Y</b>
0-12453003/25	400V/3Ph/50Hz	<b>F 560 SPECIAL Y</b>
0-12453004/25	230V/3Ph/60Hz	<b>F 560 SPECIAL Y</b>



: New or Modified Item

# HEAVY-DUTY TYRE CHANGERS



## F 560 A

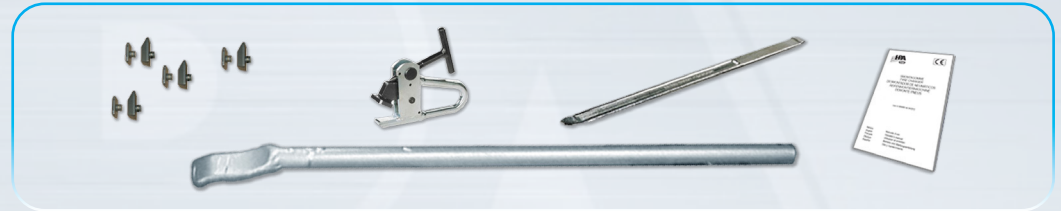

- Supplied with:
- 1 Bead lifting lever
  - 1 Rim ring lever
  - 1 Rim clamp
  - 1 Set of 4+4 special plastic inserts for jaw
  - 1 Operator's manual

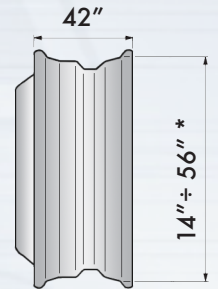

\*: with PA4V extensions

## F 560 A

PN	Power supply	Description
0-12200501/25	400V/3Ph/50Hz	<b>F 560 A</b>
0-12200502/25	230V/3Ph/60Hz	<b>F 560 A</b>
0-12200503/25	400V/3Ph/60Hz	<b>F 560 A</b>
0-12200504/25	230V/3Ph/50Hz	<b>F 560 A</b>



: New or Modified Item

# HEAVY-DUTY TYRE CHANGERS



## F 560

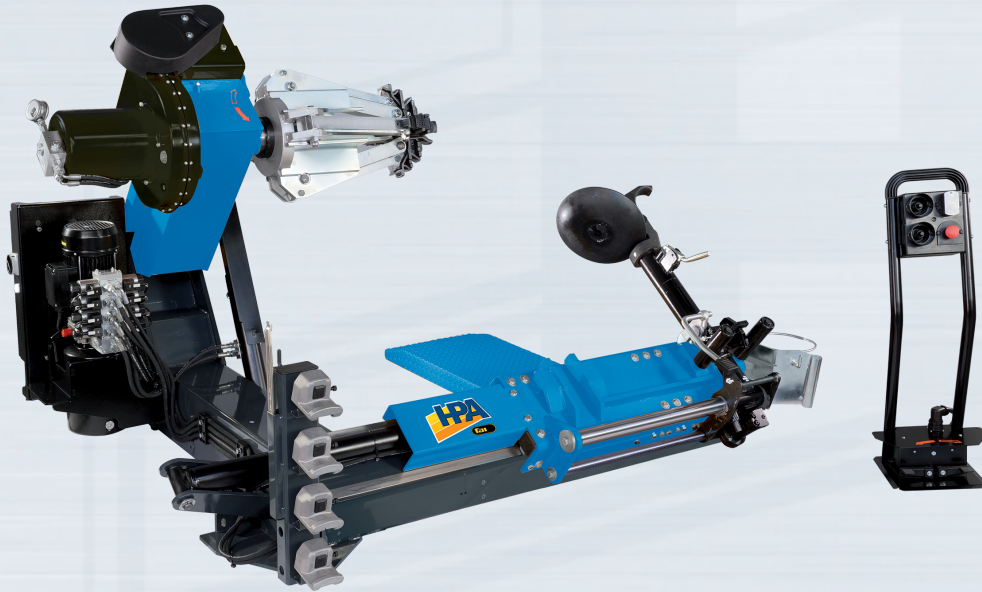

- Supplied with:
- 1 Bead lifting lever
  - 1 Rim ring lever
  - 1 Rim clamp
  - 1 Set of 4+4 special plastic inserts for jaw
  - 1 Operator's manual

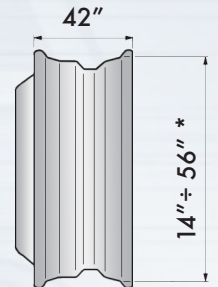

\*: with PA4V extensions

## F 560

PN	Power supply	Description
0-12200401/25	400V/3Ph/50Hz	<b>F 560</b>
0-12200402/25	230V/3Ph/60Hz	<b>F 560</b>
0-12200403/25	400V/3Ph/60Hz	<b>F 560</b>
0-12200404/25	230V/3Ph/50Hz	<b>F 560</b>



: New or Modified Item



# HEAVY-DUTY TYRE CHANGERS



## F 260

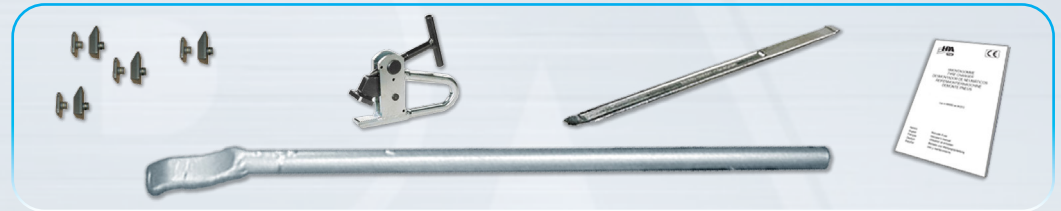

- Supplied with:
- 1 Bead lifting lever
  - 1 Rim ring lever
  - 1 Rim clamp
  - 1 Set of 4+4 special plastic inserts for jaw
  - 1 Operator's manual

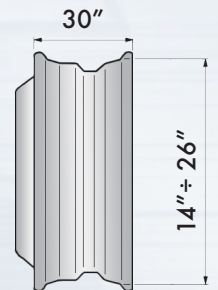

## F 260

PN	Power supply	Description
0-12423019/25	400V/3Ph/50Hz	<b>F 260</b>
0-12423021/25	230V/3Ph/60Hz	<b>F 260</b>
0-12423023/25	230V/1Ph/60Hz	<b>F 260</b>



: New or Modified Item

# HEAVY-DUTY TYRE CHANGERS



## F 240 A

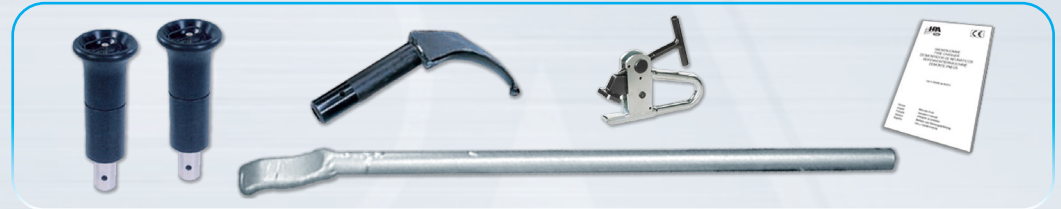
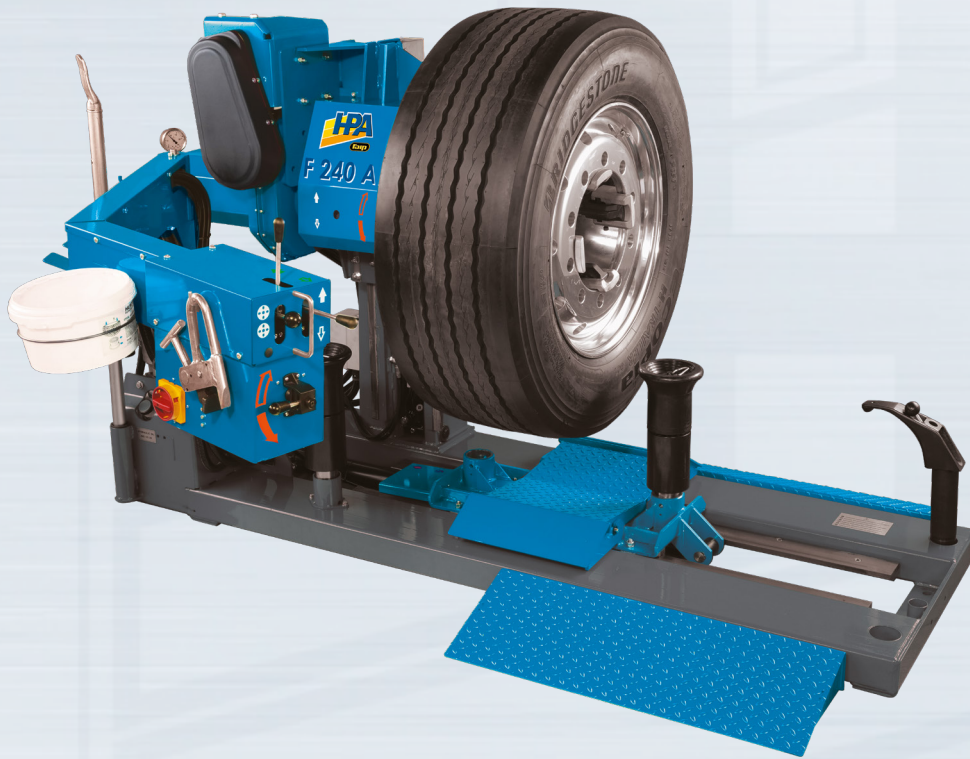

- Supplied with:
- 2 Rollers for tubeless
  - 1 Bead levering tool
  - 1 Bead lifting lever
  - 1 Rim clamp
  - 1 Operator's manual

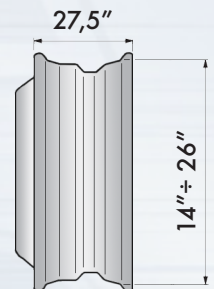

### F 240 A

PN	Power supply	Description
0-12200105/25	400V/3Ph/50Hz	<b>F 240 A</b>
0-12200106/25	230V/3Ph/60Hz	<b>F 240 A</b>
0-12200107/25	230V/1Ph/50Hz	<b>F 240 A</b>
0-12200108/25	230V/1Ph/60Hz	<b>F 240 A</b>



: New or Modified Item

# HEAVY-DUTY TYRE CHANGERS



## F 230 Mobile

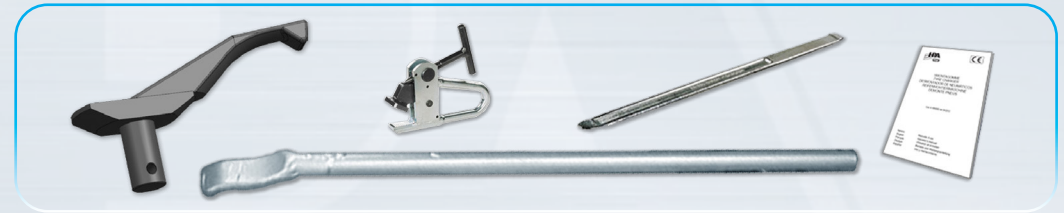

- Supplied with:
- 1 Bead levering tool
  - 1 Bead lifting lever
  - 1 Rim ring lever
  - 1 Rim clamp
  - 1 Operator's manual

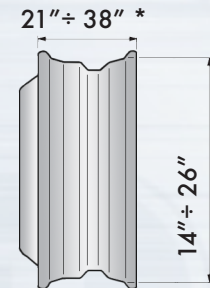

\*: Depends on wheel geometry

### F 230 MOBILE

PN	Power supply	Description
0-12200301/25	400V/3Ph/50Hz	<b>F 230 Mobile</b> for van installation - Complete with generator.
0-12200201/25	400V/3Ph/50Hz	<b>F 230 Mobile</b> for van installation - Without generator.



: New or Modified Item



# HEAVY-DUTY TYRE CHANGERS



## F 226 Mobile



- Supplied with:
- 1 Bead lever for cars
  - 1 Bead lifting lever
  - 1 Rim ring lever
  - 2 Plastic covers for bead lever
  - 1 series of locking adapters for alloy rims
  - 1 Accessory for cars and vans
  - 1 Rim clamp
  - 1 Brush
  - 1 Manual lube pump
  - 1 Operator's manual

20" ÷ 37" \*

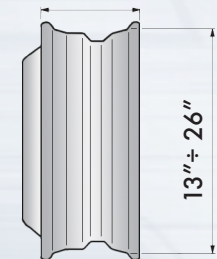

\*: Depends on wheel geometry





### F 226 MOBILE

PN	Power supply	Description
0-12101901/16	380V/3Ph/50Hz	<b>F 226 Mobile</b> RAL 3002 for van installation - Complete with generator.
0-12102201/16	380V/3Ph/50Hz	<b>F 226 Mobile</b> RAL 3002 for van installation - Without generator.
8-12100003		<b>Customization Kit</b>

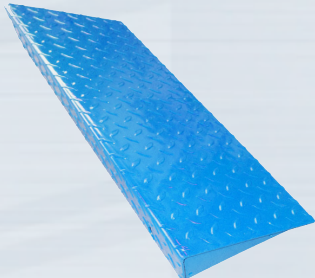

: New or Modified Item

# OPTIONAL ACCESSORIES FOR HEAVY-DUTY TYRE CHANGERS







PN	Picture	Description	F 565	F 562 - F 562 M	F 560 Special	F 560 A . F 560	F 260	F 240 A	F 230 Mobile	F 226 Mobile
8-12100039/25		<b>PC240</b> carriage platform						●		
8-12100040/25		<b>PT240</b> ramp						●		
8-12400014		<b>2.4 Ghz Trolley</b> Multichannel radio remote control kit. PLC Technology. compatible up to serial number: FUC272747		●						
8-12120025/00		<b>Radio Remote control kit</b> for F560, F560A, F562 and F562M F 560 A / F 560 compatible starting from serial number: FRCxxxxxx F 562 compatible starting from serial number: FUDxxxxxx		●		●				
8-12100026		<b>SGP</b> Radio remote control for F 560 A Special and F 560 A Special Y only.			●					

# OPTIONAL ACCESSORIES FOR HEAVY-DUTY TYRE CHANGERS

PN	Picture	Description	F 565	F 562 - F 562 M	F 560 Special	F 560 A . F 560	F 260	F 240 A	F 230 Mobile	F 226 Mobile
801271597		<b>MV50/2</b> Pair of bead clamps	●	●	●	●				
801271609		<b>RT50/2</b> Roller for tubeless.				●	●			
801280918		<b>RT56</b> Roller for tubeless.		●						
19120014		<b>RT</b> Roller for tubeless.			●					
19120016		<b>RT56 Y</b> Roller for tubeless with bearings. High performance			●					
8-12100156		<b>GL4V Set of 4</b> alloy rim clamps for new "4V" self-centering chuck (for F240A starting from serial number FRE300447)		●		●	●	●		
8-12100175		<b>KGL56 Set of 4</b> clamps for alloy rims.	●		●					
801227195		<b>PL56</b> Clamp for alloy rims.	●	●	●	●	●	●	●	●



# OPTIONAL ACCESSORIES FOR HEAVY-DUTY TYRE CHANGERS

PN	Picture	Description	F 565	F 562 - F 562 M	F 560 Special	F 560 A - F 560	F 260	F 240 A	F 230 Mobile	F 226 Mobile
8-12100155		<b>PA4V</b> Set of 4 extensions for new "4V" self-centering chuck.		●		●				
8-12100171	 x4	<b>P4P</b> Set of four 4-point extensions for wheel with side ring.	●		●					
8-12100172		<b>SPIG</b> Set of 8 + 8 spare plastic inserts for new "4V" steel clamps.		■		■	■			
8-11400200		<b>SPI</b> set of 4 + 4 + 4 spare plastic inserts for KGL56 set of 4 clamps for alloy rims.	■		■					
801217615		<b>LA24</b> Bead lifting lever.	■	■	■	■	■	■	■	■
801417620		<b>LC24</b> Rim ring lever.	■	■	■	■	■	●	■	■

# OPTIONAL ACCESSORIES FOR HEAVY-DUTY TYRE CHANGERS

PN	Picture	Description	F 565	F 562 - F 562 M	F 560 Special	F 560 A . F 560	F 260	F 240 A	F 230 Mobile	F 226 Mobile
8-12100188		<b>Extensions</b> kit for port crane rims	●		●	●				
8-12100005		<b>AB164</b> Locking adapter for alloy rims D.164.	●	●	●	●	●	●	●	●
8-12100006		<b>AB176</b> Locking adapter for alloy rims D.176.	●	●	●	●	●	●	●	●
8-12100007		<b>AB161</b> Locking adapter for alloy rims D.161.	●	●	●	●	●	●	●	●
8-12100008		<b>AB202</b> Locking adapter for alloy rims D.202.	●	●	●	●	●	●	●	●
8-12300001		<b>AB220</b> Locking adapter for alloy rims D.220.	●	●	●	●	●	●	●	●
8-12100009		<b>AB221</b> Locking adapter for alloy rims D.221.	●	●	●	●	●	●	●	●
8-12100010		<b>AB281</b> Locking adapter for alloy rims D.281.	●	●	●	●	●	●	●	●
8-12100176		<b>PA26</b> Set of four chuck extensions (for F240A up to serial number FRE300446)						●	●	
801254494		<b>PCL26</b> Set of four alloy rim protections (for F240A up to serial number FRE300446)						●	●	
801251904		Skidder <b>clamp</b>	●	●	●	●	●	●		

# OPTIONAL ACCESSORIES FOR HEAVY-DUTY TYRE CHANGERS





PN	Picture	Description	F 565	F 562 - F 562 M	F 560 Special	F 560 A . F 560	F 260	F 240 A	F 230 Mobile	F 226 Mobile
8-12100044		3 rim edge <b>plastic protections</b>	●	●	●	●	●	●	●	●
801289439		<b>RT24</b> Roller for tubeless.	■					■		
801289440		<b>UB24</b> Bead levering tool.						■		
801289441		<b>DS24</b> Bead breaking disc.						●		
8-12100030		<b>DS226</b> Bead breaking disc for rim ring for F 226/230 Mobile.							●	●
8-12100157		<b>K4V26</b> Set of clamps 4V and connecting rods to retrofit F 260.					●			
8-12100158		<b>K4V56</b> Set of clamps 4V to retrofit F 560 and F 560 A.				●				
8-12100159		<b>K4V58</b> Set of clamps 4V to retrofit F 561 and F 562.		●						

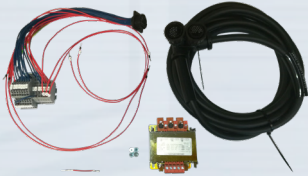

# OPTIONAL ACCESSORIES FOR HEAVY-DUTY TYRE CHANGERS

PN	Picture	Description	F 565	F 562 - F 562 M	F 560 Special	F 560 A . F 560	F 260	F 240 A	F 230 Mobile	F 226 Mobile
8-12100017		<b>BP 120</b> Air operated bead presser.	●	●	●	●	●	●	●	●
8-11400034		<b>SGG</b> Tyre paste container with brush (4 kg).	●	●	●	●	●	●		●
801280917		<b>PS56</b> Additional platform.		●						
8-12120023/90		<b>Runway platform</b> kit H=110.	●							
8-12120020		<b>2.4 Ghz</b> radio remote control kit for F230 Mobile							●	

# OPTIONAL ACCESSORIES FOR HEAVY-DUTY TYRE CHANGERS

PN	Picture	Description	F 565	F 562 - F 562 M	F 560 Special	F 560 A . F 560	F 260	F 240 A	F 230 Mobile	F 226 Mobile
8-12120024		<b>Radio Upgrade kit</b> for F230 MOBILE required to install the Radio Kit on machines preceding serial number FPM182480							●	
8-12120008/90		<b>CAR MATE</b> for light vehicles. Supplied with tool head and disc accessory.							●	
8-12120011/90		<b>Roller conveyor.</b>							●	
8-12120009		<b>Extension</b> for loading threshold H=750 mm.							●	
8-12120010		<b>Extension</b> for loading threshold H=1.000 mm.							●	

# DIAGRAM OF PACKING SPECIFICATION

## PASSENGER CAR TYRE CHANGERS

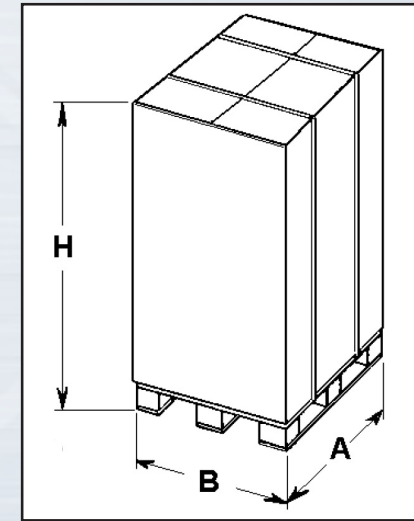
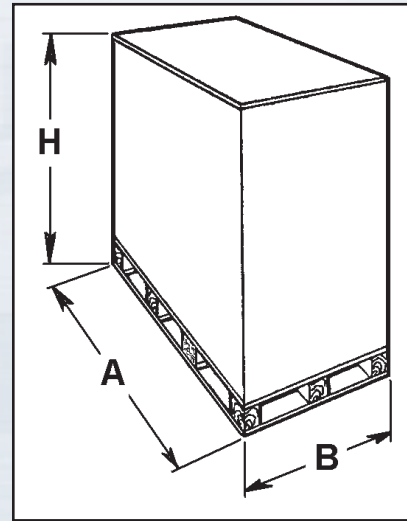

Model	Packing type	Dimensions (cm.) (A x B x H)	Net Weight (kg)	Gross Weight (kg)
<b>M 1032 (versione STD)</b>	Wooden case (A)	115x195x210	500	600
<b>M 928 ROYAL</b>	"	154x114x190	400	490
<b>M 830 LL+KWL</b>	"	132x 76x183	320	365
<b>M 824 2V FS LL</b>	"	90x115x 97	278	305
<b>M 824 LL</b>	"	90x115x 97	263	295
<b>M 624 2V FS</b>	"	99x112x102	260	290
<b>M 624</b>	"	99x112x102	245	275
<b>M 522 2V FS / M 522 FS</b>	"	99x112x102	240	270
<b>M 522 2V / M 522</b>	"	99x112x102	225	255
<b>M 424 2V FS / M 424 FS</b>	"	114x 76x 97	250	275
<b>M 424 2V / M 424</b>	"	114x 76x 97	235	260
<b>M 422 2V FS / M 422 FS</b>	Carton box on pallet base (B)	112x100x 97	225	250
<b>M 422 2V / M 422</b>	"	112x100x 97	215	240



Model	Packing type	Dimensions (cm.) (A x B x H)	Net Weight (kg)	Gross Weight (kg)
<b>M 200 BIKE</b>	"	95x115x108	155	175
<b>Accessory ALLY 80</b>	Carton box on pallet base (B)	47x154x 45	105	120
<b>Accessory ALLY 30 *</b>	"	82x120x 42	70	110
<b>Accessory ALLY 30 **</b>	"	53x120x 42	70	110

\* : Accessory with preassembled arm.

\*\* : Accessory without preassembled arm.

**DIAGRAM OF PACKING SPECIFICATION**

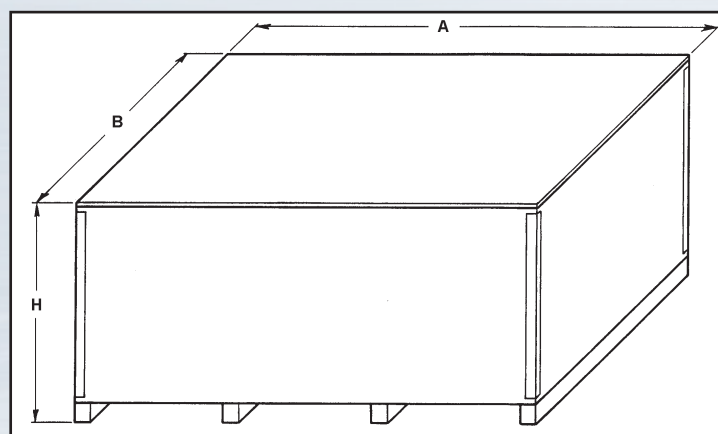

HEAVY-DUTY TYRE CHANGERS

Model	Packing type	Dimensions (cm.) (A x B x H)	Net Weight (kg)	Gross Weight (kg)
<b>F 565</b>	Wooden case	299x229x110	2500	2200
<b>F 562</b>	"	272x231x105	1410	1610
<b>F 560 A</b>	"	212x192x110	750	910
<b>F 560</b>	"	200x172x103	740	870
<b>F 260</b>	"	200x172x103	510	640
<b>F 240 A</b>	"	193x76x109	500	540



# in the world

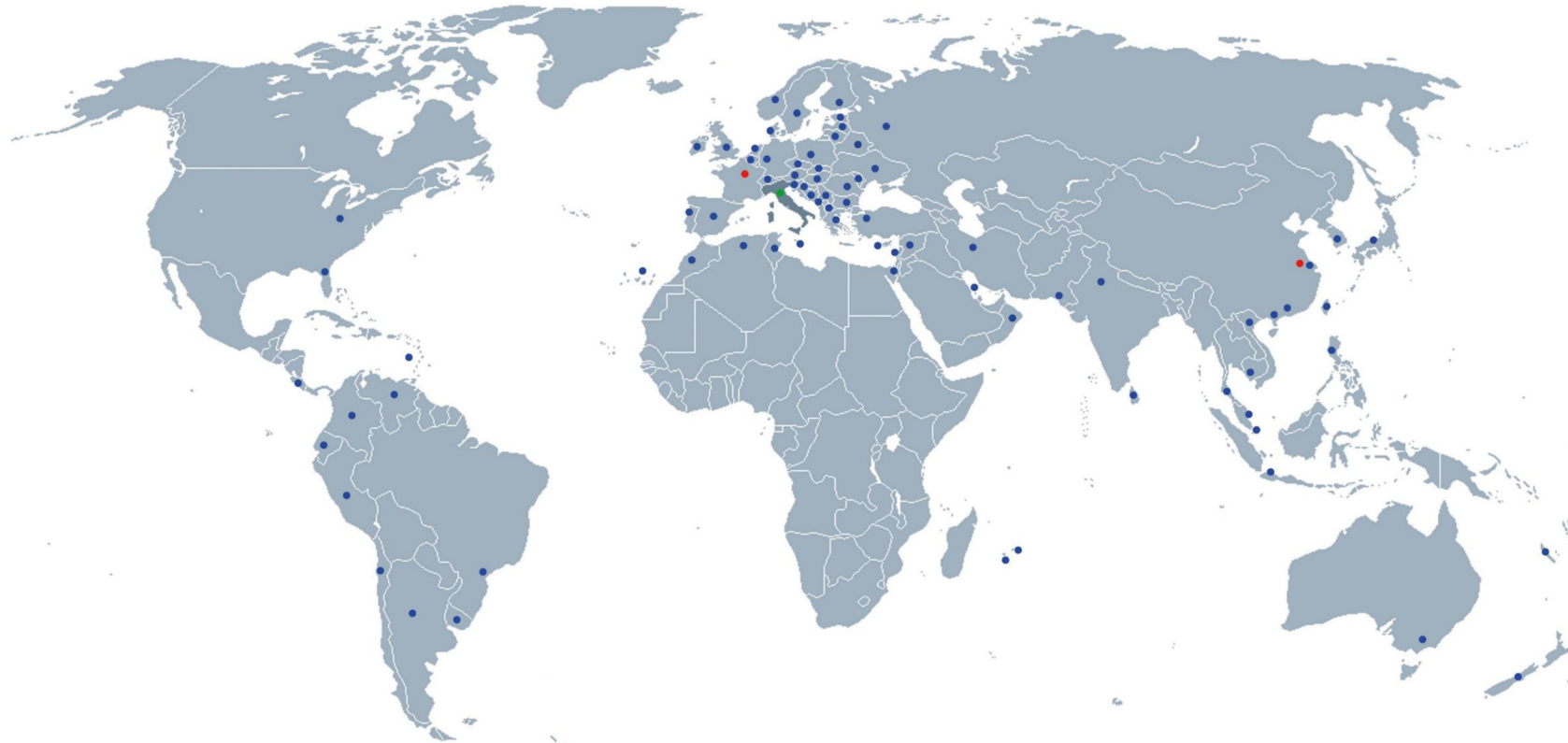

- : HPA-FAIP branch offices in the world.
- : HPA-FAIP distributors.
- : HPA-FAIP head office.

### Sales and after-sales network:

- |             |                  |                 |             |                     |                     |                      |             |
|-------------|------------------|-----------------|-------------|---------------------|---------------------|----------------------|-------------|
| ● ALGERIA   | ● CAMBODIA       | ● ECUADOR       | ● INDIA     | ● MACAO             | ● NEW ZEALAND       | ● RUSSIAN FEDERATION | ● TAIWAN    |
| ● ARGENTINA | ● CANARY ISLANDS | ● ESTONIA       | ● INDONESIA | ● MACEDONIA         | ● NORWAY            | ● SERBIA             | ● THAILAND  |
| ● AUSTRALIA | ● CHILE          | ● FINLAND       | ● IRAN      | ● MALAYSIA          | ● OMAN              | ● SINGAPORE          | ● TUNISIA   |
| ● AUSTRIA   | ● CHINA (RP)     | ● FRANCE        | ● IRELAND   | ● MALTA             | ● PAKISTAN          | ● SLOVAK REPUBLIC    | ● TURKEY    |
| ● BAHRAIN   | ● COLOMBIA       | ● GERMANY       | ● ISRAEL    | ● MARTINICA         | ● PERU              | ● SLOVENIA           | ● UKRAINE   |
| ● BELARUS   | ● COSTA RICA     | ● GREAT BRITAIN | ● JAPAN     | ● MAURITIUS         | ● PHILIPPINES (THE) | ● SPAIN              | ● URUGUAY   |
| ● BELGIUM   | ● CROATIA        | ● GREECE        | ● KOSOVO    | ● MONTENEGRO        | ● POLAND            | ● SRI LANKA          | ● U.S.A.    |
| ● BOSNIA    | ● CYPRUS         | ● HUNGARY       | ● LATVIA    | ● MOROCCO           | ● PORTUGAL          | ● SWEDEN             | ● VENEZUELA |
| ● BRAZIL    | ● CZECH REPUBLIC | ● HUNGARY       | ● LEBANON   | ● NETHERLANDS (THE) | ● REUNION ISLAND    | ● SWITZERLAND        | ● VIETNAM   |
| ● BULGARIA  | ● DENMARK        | ● KOREA (SOUTH) | ● LITHUANIA | ● NEW CALEDONIA     | ● ROMANIA           | ● SYRIA              |             |
| ● CAMBODIA  | ● ECUADOR        |                 |             |                     |                     |                      |             |



■ : New or Modified Item

# GENERAL SALES CONDITIONS

- The present export price-list, covering standard production equipment, replaces all previous ones.
- Goods are delivered FCA WAREHOUSE CORREGGIO - Incoterms® 2010, ICC Paris and shipped at buyer's cost.
- Standard packing is included in the price of each product.
- When ordering please always state model, quantity, power supply (Voltage, Phases, Hz) required.
- Terms of warranty: 12 months from installation date but no longer than 18 months from the date of NEXION S.p.A. invoice.
- The warranty does not cover defects or damages due to improper installation or use of products, inadequate maintenance or uncomplete knowledge of manuals supplied with the products.
- Any return of goods must always be authorized by NEXION S.p.A. and will be accepted only free our factory, custom cleared. Freight is at sender's risk.
- NEXION S.p.A. reserves the right to change the specifications of the products at any time without prior notice or obligation.

## WARNING!

For other conditions please refer to the "Distribution Agreement".





**COMPANY WITH  
CERTIFIED  
QUALITY SYSTEM  
- ISO 9001-**

